

Zylinderaufnahme für Bohrwerkzeuge Form E2 mit innerer Kühlmittelzuführung

DIN 69 880

Bestell- nummer	Abmessungen d1 x d2	d6	d8	h1	h2	L3	L6	Euro
E2	16 x 06	40	32	18	18	13	44	60,00 €
E2	16 x 08	40	32	18	18	13	44	60,00 €
E2	16 x 10	40	32	18	18	13	44	60,00 €
E2	16 x 12	40	40	18	18	13	44	60,00 €
E2	16 x 16	40	40	18	18	13	44	60,00 €
E2	20 x 08	50	40		23	18	50	60,00 €
E2	20 x 10	50	40		23	18	50	60,00 €
E2	20 x 12	50	40		23	18	50	60,00 €
E2	20 x 16	50	40		23	18	50	60,00 €
E2	20 x 20	50	50		23	18	50	60,00 €
E2	20 x 25	50	50		23	18	60	60,00 €
E2	25 x 08	58	40	25	25	18	50	62,00 €
E2	25 x 10	58	40	25	25	18	50	62,00 €
E2	25 x 12	58	40	25	25	18	50	62,00 €
E2	25 x 16	58	40	25	25	18	50	62,00 €
E2	25 x 20	58	58	25	25	18	50	62,00 €
E2	25 x 25	58	58	25	25	18	60	62,00 €
E2	30 x 08	68	55	28	30	22	60	60,00 €
E2	30 x 10	68	55	28	30	22	60	60,00 €
E2	30 x 12	68	55	28	30	22	60	60,00 €
E2	30 x 16	68	55	28	30	22	60	60,00 €
E2	30 x 20	68	55	28	30	22	60	60,00 €
E2	30 x 25	68	55	28	30	22	60	60,00 €
E2	30 x 32	68	68	28	30	22	75	60,00 €
E2	30 x 40	68	68	28	30	22	90	60,00 €

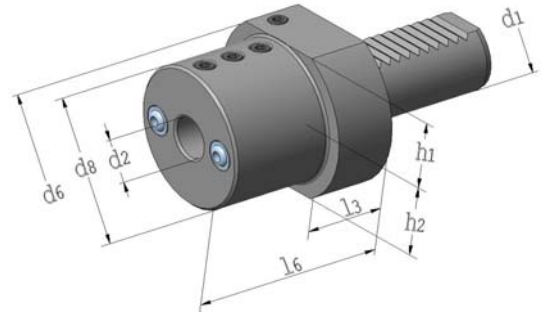

Bestell- nummer	Abmessungen d1 x d2	d6	d8	h1	h2	L3	L6	Euro
E2	40 x 08	83	55	32,5		22	75	60,00 €
E2	40 x 10	83	55	32,5		22	75	60,00 €
E2	40 x 12	83	55	32,5		22	75	60,00 €
E2	40 x 16	83	55	32,5		22	75	60,00 €
E2	40 x 20	83	55	32,5		22	75	60,00 €
E2	40 x 25	83	55	32,5		22	75	60,00 €
E2	40 x 32	83	83	32,5		22	75	60,00 €
E2	40 x 40	83	83	32,5		22	90	60,00 €
<hr/>								
E2	50 x 12	98	68	35		30	90	82,00 €
E2	50 x 16	98	68	35		30	90	82,00 €
E2	50 x 20	98	68	35		30	90	82,00 €
E2	50 x 25	98	68	35		30	90	82,00 €
E2	50 x 32	98	68	35		30	90	82,00 €
E2	50 x 40	98	68	35		30	90	82,00 €
E2	50 x 50	98	68	35		30	100	82,00 €

