

## Axial -Werkzeughalter Form C1 rechts

DIN 69 880

Bestellnummer	Abmessungen	Euro
d1 x h1 x L1	b1 b2 b3 L2 h5 h6	
C1/16	16 x 12 x 44 43 24 13 5 20 22	62,00
C1/20	20 x 16 x 50 52 27 13 7 25 30	64,00
C1/25	25 x 16 x 55 58 33 19 7 25 30	72,00
C1/30	30 x 20 x 70 70 35 17 10 28 38	64,00
C1/40	40 x 25 x 85 85 42,5 21 12,5 32,5 48	76,00
C1/50	50 x 32 x 100 100 50 26 16 35 60	97,00

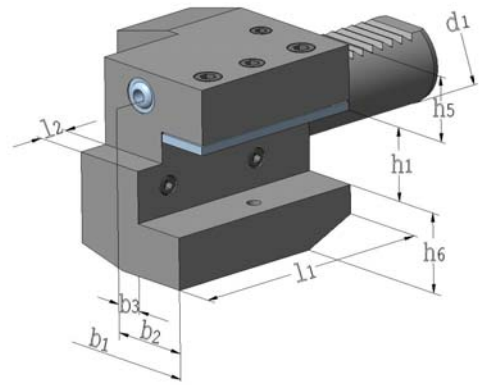

## Axial -Werkzeughalter Form C2 links

DIN 69 880

Bestellnummer	Abmessungen	Euro
d1 x h1 x L1	b4 b5 b6 L2 h5 h6	
C2/16	16 x 12 x 44 43 24 13 5 20 22	62,00
C2/20	20 x 16 x 50 65 40 26 7 25 30	64,00
C2/25	25 x 16 x 55 58 33 19 7 25 30	72,00
C2/30	30 x 20 x 70 76 41 23 10 28 38	64,00
C2/40	40 x 25 x 85 90 47,5 25,5 12,5 32,5 48	76,00
C2/50	50 x 32 x 100 105 55 30,5 16 35 60	97,00

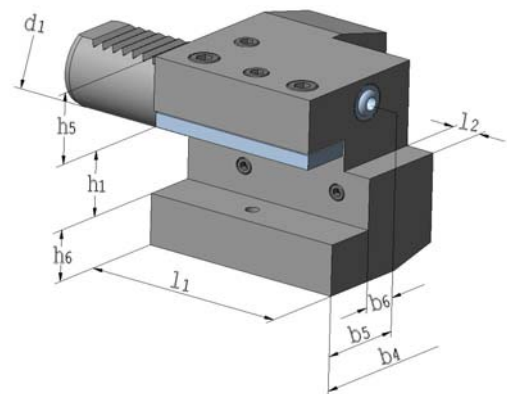

## Axial -Werkzeughalter Form C3 Überkopf rechts

DIN 69 880

Bestellnummer	Abmessungen	Euro
d1 x h1 x L1	b1 b2 b3 L2 h6 h7	
C3/16	16 x 12 x 44 43 24 13 5 22 20	64,00
C3/20	20 x 16 x 50 52 27 13 7 30 25	66,00
C3/25	25 x 16 x 55 58 33 19 7 30 25	74,00
C3/30	30 x 20 x 70 70 35 17 10 38 35	71,00
C3/40	40 x 25 x 85 85 42,5 21 12,5 48 42,5	78,00
C3/50	50 x 32 x 100 100 50 26 16 60 50	99,00

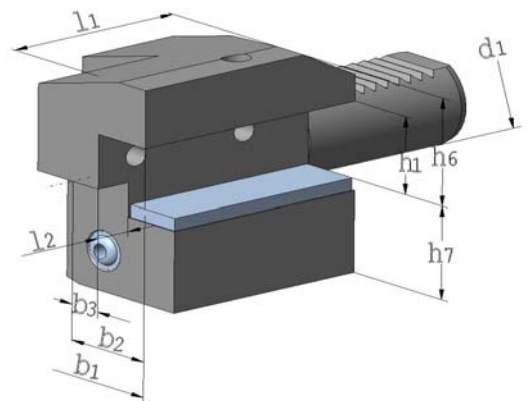

## Axial -Werkzeughalter Form C4 Überkopf links

DIN 69 880

Bestellnummer	Abmessungen	Euro
d1 x h1 x L1	b4 b5 b6 L2 h5 h6	
C4/16	16 x 12 x 44 43 24 13 5 22 20	64,00
C4/20	20 x 16 x 50 65 40 26 7 30 25	66,00
C4/25	25 x 16 x 55 58 33 19 7 30 25	74,00
C4/30	30 x 20 x 70 76 41 23 10 38 35	71,00 €
C4/40	40 x 25 x 85 90 47,5 25,5 12,5 48 42,5	78,00
C4/50	50 x 32 x 100 105 50 30,5 16 60 50	99,00

